

Mamasa_Watershed_Towards_ Bakaru_Power_Plan_Water_Res ources.pdf

by

Submission date: 22-Oct-2022 05:48AM (UTC+0700)

Submission ID: 1931927899

File name: Mamasa_Watershed_Towards_Bakaru_Power_Plan_Water_Resources.pdf (579.26K)

Word count: 3970

Character count: 18478

Real-Time Optimal Power Flow of South Sulawesi Network System That Integrated Wind Power Plant Based on Artificial Intelligence

Abstract. The development and utilization of technology are always directly proportional to the need for electrical energy. Real-time power flow research is used to evaluate the effect of wind power generation fluctuations on existing conventional systems. This research was conducted on the South Sulawesi electricity network system using Modified Improved Particle Swarm Optimization (MIPSO). The real-time results show that the power loss in the conventional system that is interconnected with wind power plants is 63.9208 WM, less than the power loss in the conventional system, which is 85.9440 WM. Likewise, the cost of the generating system connected to a wind power plant is \$23368.6622/hour, lower than the conventional system power of \$23503.444/hour, reducing costs or efficiency by 0.5735%/hour. Real-time analysis of optimal power flow with MIPSO can be used to determine the effect of changes in power generated by wind power plants on the conventional power grid system of Southwest Sulawesi.

Streszczenie. Rozwój i wykorzystanie technologii są zawsze wprost proporcjonalne do zapotrzebowania na energię elektryczną. Badania przepływu mocy w czasie rzeczywistym służą do oceny wpływu wahań generacji wiatrowej na istniejące systemy konwencjonalne. Badania przeprowadzono na systemie sieci elektroenergetycznej Południowego Sulawesi przy użyciu metody Modified Improved Particle Swarm Optimization (MIPSO). Wyniki w czasie rzeczywistym pokazują, że strata mocy w systemie konwencjonalnym, który jest połączony z elektrowniami wiatrowymi, wynosi 63.9208 WM, czyli mniej niż strata mocy w systemie konwencjonalnym, która wynosi 85.9440 WM. Podobnie, koszt systemu wytwórczego podłączonego do elektrowni wiatrowej wynosi 233686622 USD/godz., czyli jest niższy niż konwencjonalna moc systemu wynosząca 23503,444 USD/godz., co zmniejsza koszty lub wydajność o 0,5735%/godz. Analiza w czasie rzeczywistym optymalnego przepływu mocy za pomocą MIPSO może być wykorzystana do określenia wpływu zmian mocy generowanej przez elektrownie wiatrowe na konwencjonalny system sieci energetycznej południowo-zachodniego Sulawesi. (Optymalny przepływ mocy w czasie rzeczywistym w systemie sieci South Sulawesi, który zintegrował elektrownię wiatrową w oparciu o sztuczną inteligencję)

Keywords: Real-time, OPF, MIPSO

Słowa kluczowe: przepływ mocy, optymalizacja, czas rzeczywisty

Introduction

Nowadays, electrical energy is increasing along with technological developments that demand that electrical systems can work optimally. The variables used at optimal power flow include quality, stability, reliability, and economy. The generation system is expected to be able to continuously flow quality electrical energy by the standard voltage, and frequency levels that have been set at a low cost. And if there is interference, then the system can return to work normally.

Generally, the calculation of the Optimal Power Flow is an effort made to increase the quality of the electrical system from a technical and economic perspective. Optimal Power Flow is a very important issue in operation, and power system planning [1]. The methods used in the calculations include the solutions introduced by Carpentier J ante to the issue of economic dispatch in Bulletin of Society Francaise Electricians vol. 3, pp.431-474, 1962. This solution inspired several researchers in developing formulations for OPF including, Non-Linear Programming (NLP) [2], Gray-Wolf Optimization (GWO) [3], Power cones [4], ANN-based on PSO for Microgrid Optimal Energy Scheduling [5]. And several methods based on PSO [6, 7].

This study uses data from the South Sulawesi system of 44 buses, 13 conventional generator buses, 2 wind power generator buses, and the remaining 29 load buses. The method used in calculating OPF is MIPSO.

Optimal Power Flow

The most commonly used optimal power flow to minimize an objective function is $F(x,u)$ which satisfies the constraints $g(x,u)=0$ and $h(x,u)\leq 0$, where the function $g(x,u)$ for nonlinear equality (nonlinear equality constraints), while the function $h(x,u)$ is for inequalities (nonlinear inequality constraints). The vector x is the variable voltage

magnitude, the phase angle, and the Mvar output from the generator, a fixed value parameter such as the phase angle on the reference bus, line parameter, and others. The vector u is a control variable such as active and reactive power [8, 9, 10].

Economic Dispatch Equation Model.

There are several models for calculating economic dispatch in the electric power system [11, 12, 13]. The formula used in calculating the cost for each generator is as follows.

$$(1) F_T = \sum_{i=1}^n F_i(P_i)$$
$$(2) F_i(P_i) = a_i + b_i P_i + c_i P_i^2$$

where :

F_T - total generation cost (\$), $F_i(P_i)$ - input-output cost function of generator i (\$/hour), a_i, b_i, c_i - cost coefficient of generator, n - number of generating units, i, P_i - output of generator i (MW), i - index of dispatchable units.

Calculation of power balance using the formula:

$$(3) \sum_{i=1}^n P_i = P_D$$

Limitation of generating capacity with the following formula

$$(4) P_{min} \leq P_i \leq P_{max}$$

where :

$P_{i\ min}$ - minimum, and maximum the power output of generator i .

PSO, MIPSO, and MIPSO

In 1995, Kennedy and Eberhart compiled a new algorithm called Particle Swarm Optimization which is abbreviated as PSO [14]. They imitate the pattern of life of a group of animals, such as fish, birds, and other animal life groups. The PSO formula is as follows.

$$(6) \quad v_{id}^{k+1} = v_{id}^k + c_1 r_1^k (Pbest_{id}^k - x_{id}^k) + c_2 r_2^k (Gbest_d^k - x_{id}^k),$$

and

$$(7) \quad x_{id}^{k+1} = x_{id}^k + v_{id}^{k+1}$$

where :

v_{id}^k - particle velocity i dimensions d at k , v_{id}^{k+1} - particle velocity i , dimension d at $k+1$, x_{id}^k - particle position i dimensions d at k , x_{id}^{k+1} - particle position i dimensions d at $k+1$, r_1^k, r_2^k - random value between 0 and 1, c_1, c_2 - acceleration coefficient, $Pbest_{id}^k$ - best position of local particle i on k , $Gbest_{id}^k$ - global best position of particle i on k .

In 1998, Shi and Eberhart modified PSO known as Modified Particle Swarm Optimization (MPSO) by applying inertia weight to maintain the balance of local and global searches to provide good performance on PSO [15, 16, 17]. The dynamic equation of PSO, velocity is modified to:

$$(8) \quad v_{id}^{k+1} = w v_{id}^k + c_1 r_1^k (Pbest_{id}^k - x_{id}^k) + c_2 r_2^k (Gbest_d^k - x_{id}^k)$$

with,

$$(9) \quad w(i) = w_{max} - \left(\frac{w_{max} - w_{min}}{i_{max}} \right) i$$

Where :

$w(i)$ - inertia weight on i , $w_{max} - w_{min}$ - inertia weight from start to finish, i_{max} - maximum epoch, i - current.

Clerc M (1999) applied the constriction factor known as Constriction Factor Based Particle Swarm Optimization (CFBPSO). These improvements and modifications aim to ensure a trace in the PSO algorithm for faster convergence [18, 19, 20, 21]. The dynamic equation of PSO, velocity is modified and improved to:

$$(10) \quad v_{id}^{k+1} = CF v_{id}^k + c_1 r_1^k (Pbest_{id}^k - x_{id}^k) + c_2 r_2^k (Gbest_d^k - x_{id}^k)$$

with

$$(11) \quad CF = \frac{2}{2 - \varphi + \sqrt{\varphi^2 - 4\varphi}}$$

and

$\varphi = c_1 + c_2$, and $\varphi > 4$

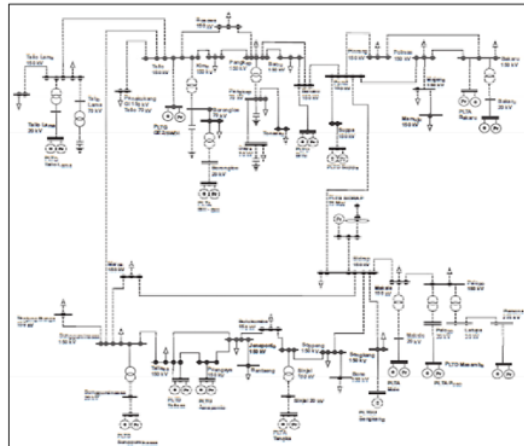

Figure 1. Single line electricity network system for South West Sulawesi

Materials and Method

Materials

This study uses data from the Southwest Sulawesi Electrical System which is interconnected with wind power plants in Sidrap and Jeneponto Regencies. Generator

buses, namely Pinrang, Sidrap (wind power plant), Suppa, Barru, Borongloe, Tello, Tallasa, Jeneponto (wind power plant), Punagaya, Sinjai, Makale, Sengkang, Palopo, Poso, the remaining 29 buses are load buses, Bakaru is slack buses.

The first analysis uses conventional generator data, namely as many as 13 bus generators. And the second analysis uses conventional data systems that are interconnected with two wind power plants, namely Sidrap and Jeneponto Wind Power Plant.

The single-line electricity network for the South-West Sulawesi system can be seen in Figure 1.

Method

The method used is MIPSO. In this study, the variables studied are active power, losses, and generation costs. Simulations were carried out on hourly data to determine the effect of wind power plants on the variables studied.

To further clarify the stages of the research carried out, a research flowchart is made which can be seen in Figure 2 below.

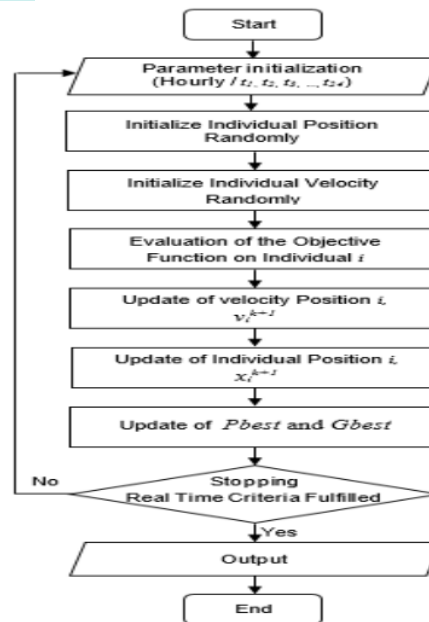

Figure 2. Research flow chart

Results and Discussion

This study simulates conventional data systems and conventional data integrated with wind power plants.

Simulation Result of Conventional System

The results of the conventional system simulation can be seen in the following table.

Table 1. Simulation results of the conventional 13 bus generator system

Generators	Power Generation (MW)
Bakaru	216.9000
Pinrang	9.1785
Suppa	20.6880
PLTU Barru	59.9670
Tello 150	6.7015
Borongloe	10.5140
Tallasa	60.1060
Punagaya	126.4700
Sinjai	6.3010

Sengkang	222.2900
Makale	12.4760
Palopo	4.5536
PLTA Poso	77.8520
Total Power Generation (MW)	833.9976
Total Load (MW)	748.0600
Losses (MW)	85.9440
Generation Cost (\$/hr)	23503.4442

The results showed that the highest generation of the Sengkang bus generator was 222.2900 MW, while the lowest was the Palopo bus generator of 4.5536 MW. The total power generation is 860,6950 MW, with a total load of 748,0600 MW, and a power loss of 85.9440 MW. The generation cost is \$ 23503.4442.

Real-time System Simulation Results

Table 2. Real-time simulation results of the South West Sulawesi network system connected to wind power plants

Time	Power Generator (MW)															Total P (MW)	Load (MW)	P Losses (MW)	Generation Cost (\$/hr)
	1	2	3	4	5	6	7	8	9	10	11	12	13	14	15				
	Bakaru	Pinrang	Suppa	Wind Sid	PLTU Barru	Tello 150	Borongloe	Tallasa	Punagaya	Wind Jp	Sinjai	Sengkang	Makale	Palopo	PLTA Poso				
1	60.72	6.38	19.04	0.35	64.42	15.77	17.05	95.41	103.11	6.41	4.58	257.76	6.31	7.25	140.79	805.34	748.06	57.28	23312.71
2	57.09	9.07	31.43	0.39	72.81	18.01	13.58	86.16	57.30	8.74	4.90	298.87	12.45	5.06	136.58	812.44	748.06	64.38	22454.67
3	69.41	11.40	22.91	2.33	58.53	12.12	19.21	67.30	93.70	29.84	3.87	247.17	6.91	5.11	166.56	816.37	748.06	68.31	22741.57
4	67.99	5.82	28.79	2.50	38.68	18.26	9.70	69.29	93.96	14.58	5.81	309.27	6.91	5.47	134.23	811.28	748.06	63.22	23262.71
5	72.24	6.25	23.47	0.67	53.82	24.95	19.06	75.28	81.46	8.15	5.19	271.08	5.15	6.40	163.25	816.43	748.06	68.37	23226.63
6	88.99	6.64	26.90	2.05	52.90	11.55	12.24	60.10	92.56	14.55	6.86	292.61	8.27	1.71	133.59	811.49	748.06	64.38	22454.67
7	72.08	7.51	30.91	0.35	64.33	16.71	6.17	84.47	95.19	18.48	4.95	252.22	9.79	4.48	139.31	806.95	748.06	58.89	22535.72
8	72.12	6.17	19.70	0.00	58.31	16.19	9.44	64.44	100.79	4.47	7.16	326.95	5.41	2.84	113.15	807.14	748.06	59.08	24430.73
9	77.12	8.31	23.89	0.71	66.32	17.90	16.83	87.46	75.78	0.00	5.16	305.90	9.99	6.56	99.88	801.81	748.06	53.75	22653.11
10	69.70	15.77	25.97	0.09	45.69	15.25	15.60	81.25	85.97	0.00	2.53	285.36	8.54	5.04	163.27	820.03	748.06	64.38	24054.02
11	83.62	8.57	20.81	0.73	47.49	17.72	9.23	57.67	90.19	0.00	6.15	335.37	6.77	2.30	128.28	814.89	748.06	66.83	25030.82
12	82.86	8.74	28.69	0.89	21.97	21.51	14.12	62.54	90.54	0.00	9.13	315.59	12.27	7.60	140.30	816.75	748.06	68.69	24199.02
13	102.01	5.74	19.03	3.16	50.96	17.01	14.62	72.44	106.52	0.00	6.51	258.92	11.41	0.32	140.10	808.77	748.06	60.71	24670.63
14	68.84	5.80	22.90	5.29	53.01	4.37	10.26	80.77	108.33	5.69	6.50	290.67	6.91	4.67	137.10	810.91	748.06	62.85	24374.70
15	63.09	6.64	32.41	6.16	49.04	15.04	13.35	79.12	104.63	1.54	7.11	289.41	6.00	5.85	126.93	806.32	748.06	58.26	23178.41
16	73.60	9.03	23.21	9.59	62.68	14.65	14.07	69.03	98.46	9.80	9.44	258.82	6.56	1.98	151.01	811.93	748.06	63.87	23171.01
17	75.47	17.55	32.56	33.22	50.11	9.36	11.42	70.07	99.89	0.36	8.91	250.27	9.33	6.34	136.30	811.19	748.06	63.13	21720.24
18	90.59	6.17	19.22	11.79	37.84	8.40	16.13	53.53	104.17	9.89	5.31	304.34	8.10	1.42	137.82	814.72	748.06	66.67	24709.52
19	72.88	5.46	19.04	15.11	38.30	8.87	14.59	78.51	95.08	12.70	5.75	279.48	7.60	7.88	156.34	817.60	748.06	69.54	23463.31
20	83.03	8.17	24.10	19.66	45.16	11.91	16.39	74.70	80.12	6.39	6.49	294.73	4.53	4.60	131.09	811.08	748.06	63.02	22558.34
21	102.89	5.77	25.13	23.63	31.57	18.54	14.30	34.43	115.39	3.55	10.15	284.94	8.30	5.67	128.14	812.42	748.06	64.36	24545.43
22	77.50	6.99	12.97	21.88	65.30	6.54	15.27	81.22	57.79	19.97	8.84	275.84	11.37	6.93	149.12	817.53	748.06	69.47	22401.10
23	56.47	11.77	21.04	23.25	51.07	17.17	20.14	77.64	90.13	20.22	2.74	255.94	9.68	3.32	149.76	810.33	748.06	62.27	21217.15
24	72.11	7.81	5.47	18.14	26.31	13.10	16.32	70.97	120.35	11.41	10.42	259.74	12.19	5.83	170.28	820.46	748.06	72.40	24896.86

Comparison of Simulation Results

Simulation results of conventional system data and systems that are interconnected with wind power plants can provide information about the effect of wind power plants on power flow in the system. More details can be seen in Table 3 below.

Table 3. Comparison of simulation results of conventional systems and interconnected systems with wind power plants.

No	Generator	Conventional System	Conventional System + Wind Power Plants
1	Bakaru	216.9	75.5178
2	Pinrang	9.1785	8.2219
3	Suppa	20.6880	23.3166
4	PLBT Sidrap	-	8.4148
5	PLTU Barru	59.9670	50.2758
6	Tello 150	6.7015	14.6209
7	Borongloe	10.5140	14.1290
8	Tallasa	60.1060	72.2425
9	Punagaya	126.4700	93.3920
10	PLTB Jeneponto	-	8.6133
11	Sinjai	6.3010	6.4360
12	Sengkang	222.2900	283.3857
13	Makale	12.4760	8.3651
14	Palopo	4.5536	4.7765
15	PLTA Poso	77.8520	140.5492
Power Generation (MW)		833.9976	812.2571
Load (MW)		748.0600	748.0600
Losses (MW)		85.9440	63.9208
Generation Cost (\$/hr)		23503.4440	23368.6622

The results of the real-time optimal power flow research using the South West Sulawesi data system which is interconnected with the Sidrap and Jeneponto Wind Power Plants show fluctuating results, this is caused by the intermittent power of the Wind Power Plant. The Sidrap Wind Power Plant (table 2 generator number 4) is highest at 17.00, which is 33.22 MW, and the lowest generation occurs at 08.00, which is 0.00 MW. Meanwhile, the highest generating power of the Jeneponto Wind Power Plant (table 2 generator number 10) at 03.00 is 29.84 MW, and the lowest generating power is at 09, 10, 11, 12, 13, namely 0.00 MW. For more details, the power generation system that is interconnected with wind power plants can be seen in Table 2 below.

The comparison simulation results between conventional systems and conventional systems that are integrated with wind power plants can be used as an

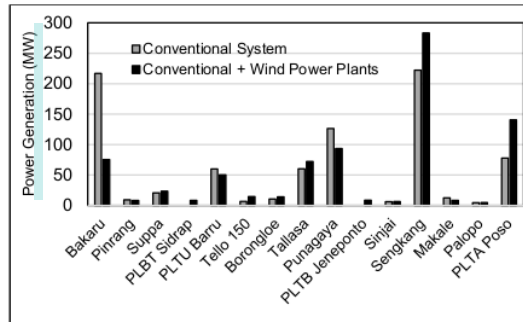

Figure 3. Generating power graph indicator of system quality.

The research that has been done shows that there is an improvement in the quality of the system after interconnection with wind power plants. Two variables can be seen from the simulation results, namely power loss and generation costs. The power loss in a conventional system that is interconnected with a wind power plant is 63.9208 WM, lower than that of a conventional system of 85.9440 WM. Likewise, the cost of generating a conventional system

that is interconnected with wind power is lower at \$ 23,368,6622 / hour compared to the conventional system which is \$ 23,503.4440/hour. The comparison results above show that there is a decrease in generation costs by 0.5735% per hour.

This graph is the average value of the real-time simulation results. The graph above shows that the highest generating power is the Sengkang generator. The total power of the conventional system is 222.2900 MW, and the interconnected conventional system is 283.3857 MW. While the lowest power generation is Palopo.

Conclusion

1. The reduction in generation costs in conventional systems that are interconnected with wind power plants is caused by the supply of power from wind power plants.
2. The decrease in power losses is due to the more even distribution of power after interconnection with wind power plants.
3. It is necessary to do further research on real-time analysis of the interconnected system of wind power plants.

Authors: Andi Muhammad ILYAS^{1,2}, Ansar SUYUTI¹, Indar Chaerah GUNADIN¹, 4. Sri Mawar SAID¹
 Department of Electrical Engineering, Faculty of Engineering University of Hasanuddin Makassar Indonesia (1), Department of Electrical Engineering, Faculty of Engineering, Khairun University, Ternate, North Moluccas, Indonesia (2).
 Email: aamilyas@gmail.com

REFERENCES

- [1] S. Li, W. Gong, C. Hu, X. Yan, L. Wang, and Q. Gu, "Adaptive constraint differential evolution for optimal power flow," *Energy*, vol. 235, p. 121362, 2021, DOI: 10.1016/j.energy.2021.121362.
- [2] J. S. Ferreira, E. J. de Oliveira, A. N. de Paula, L. W. de Oliveira, and J. A. Passos Filho, "Optimal power flow with security operation region," *Int. J. Electr. Power Energy Syst.*, vol. 124, no. June 2020, p. 106272, 2021, doi: 10.1016/j.ijepes.2020.106272.
- [3] S. Claeys, G. Deconinck, and F. Geth, "Voltage-Dependent Load Models in Unbalanced Optimal Power Flow Using Power Cones," *IEEE Trans. Smart Grid*, vol. 12, no. 4, pp. 2890–2902, 2021, doi: 10.1109/TSG.2021.3052576.
- [4] R. Jamal, B. Men, and N. H. Khan, "A Novel Nature Inspired Meta-Heuristic Optimization Approach of GWO Optimizer for Optimal Reactive Power Dispatch Problems," *IEEE Access*, vol. 8, pp. 202596–202610, 2020, doi: 10.1109/ACCESS.2020.3031640.
- [5] M. Abdolrasol, R. Mohamed, M. Hannan, A. Al-Shetwi, M. Mansor, and F. Blaabjerg, "Artificial Neural Network Based Particle Swarm Optimization for Microgrid Optimal Energy Scheduling," *IEEE Trans. Power Electron.*, vol. 36, no. 11, pp. 12151–12157, 2021, doi: 10.1109/TPEL.2021.3074964.
- [6] W. Deng, J. Xu, H. Zhao, and Y. Song, "A Novel Gate Resource Allocation Method Using Improved PSO-Based QEA," *IEEE Trans. Intell. Transp. Syst.*, pp. 1–9, 2020, doi: 10.1109/tits.2020.3025796.
- [7] Z. Xin-gang, L. Ji, M. Jin, and Z. Ying, "An improved quantum particle swarm optimization algorithm for environmental economic dispatch," *Expert Syst. Appl.*, vol. 152, 2020, doi: 10.1016/j.eswa.2020.113370.
- [8] J. A. Momoh, "Adaptive Stochastic Optimization Techniques with Applications," *Adaptive Stochastic Optimization Techniques with Applications*. pp. 1–405, 2015, doi: 10.1201/b19256.
- [9] A. Siswanto, A. Suyuti, I. Chaerah Gunadin, and S. Mawar Said, "Steady state stability limit assessment when wind turbine penetrated to the systems using REI approach," *Prz. Elektrotechniczny*, vol. 95, no. 6, pp. 51–55, 2019, doi: 10.15199/48.2019.06.10.
- [10] S. Manjang and Y. A. Rahman, "Distributed photovoltaic integration as complementary energy: Consideration of solutions for power loss and load demand growth problems," *Prz. Elektrotechniczny*, vol. 96, no. 9, pp. 56–61, 2020, doi: 10.15199/48.2020.09.12.
- [11] B. Dey, B. Bhattacharyya, and F. P. G. Márquez, "A hybrid optimization-based approach to solve environment constrained economic dispatch problem on microgrid system," *J. Clean. Prod.*, vol. 307, no. May, 2021, doi: 10.1016/j.jclepro.2021.127196.
- [12] M. Zare, M. R. Narimani, M. Malekpour, R. Azizpanah-Abarghoee, and V. Terzija, "Reserve constrained dynamic economic dispatch in multi-area power systems: An improved fireworks algorithm," *Int. J. Electr. Power Energy Syst.*, vol. 126, no. PA, p. 106579, 2021, doi: 10.1016/j.ijepes.2020.106579.
- [13] A. Goudarzi, Y. Li, and J. Xiang, "A hybrid non-linear time-varying double-weighted particle swarm optimization for solving non-convex combined environmental economic dispatch problem," *Appl. Soft Comput. J.*, vol. 86, no. XXXX, p. 105894, 2020, doi: 10.1016/j.asoc.2019.105894.
- [14] Kennedy, "Particle Swarm Optimization (PSO)," 1995.
- [15] Y. P. Zhou, L. J. Tang, J. Jiao, D. D. Song, J. H. Jiang, and R. Q. Yu, "Modified particle swarm optimization algorithm for adaptively configuring globally optimal classification and regression trees," *J. Chem. Inf. Model.*, vol. 49, no. 5, pp. 1144–1153, 2009, doi: 10.1021/ci800374h.
- [16] M. Clerc, "The swarm and the queen: Towards a deterministic and adaptive particle swarm optimization," *Proc. 1999 Congr. Evol. Comput. CEC 1999*, vol. 3, pp. 1951–1957, 1999, doi: 10.1109/CEC.1999.785513.
- [17] T. Y. Lee, "Operating schedule of battery energy storage system in a time-of-use rate industrial user with wind turbine generators: A multipass iteration particle swarm optimization approach," *IEEE Trans. Energy Convers.*, vol. 22, no. 3, pp. 774–782, 2007, doi: 10.1109/TEC.2006.878239.
- [18] D. P. Li, G. L. Shen, W. D. Guo, Zh. Zhang, B. N. Hu, and W. Gao, "Power system reactive power optimization based on MIPSO," *Energy Procedia*, vol. 14, pp. 788–793, 2012, doi: 10.1016/j.egypro.2011.12.1012.
- [19] M. Lu and M. Zhao, "The Research of Wind-thermal Power Random Multi-objective Scheduling Based on Combined MIPSO," *Int. J. Hybrid Inf. Technol.*, vol. 6, no. 6, pp. 359–368, 2013, doi: 10.14257/ijhit.2013.6.6.32.
- [20] Andi Muhammad Ilyas; M Natsir Rahman, "Economic Dispatch Thermal Generator Using Modified Improved Particle Swarm Optimization," *TELKOMNIKA (Telecommunication Comput. Electron. Control.*, vol. 10, no. Energy, pp. 459–470, 20012.
- [21] S. Y. Lim, M. Montakhab, and H. Nouri, "A constriction factor based particle swarm optimization for economic dispatch," *ESM 2009 - 2009 Eur. Simul. Model. Conf. Model. Simul.* 2009, no. Gaing, pp. 305–311, 2009.

ORIGINALITY REPORT

9%

SIMILARITY INDEX

7%

INTERNET SOURCES

6%

PUBLICATIONS

1%

STUDENT PAPERS

PRIMARY SOURCES

1	www.pe.org.pl Internet Source	3%
2	res.mdpi.com Internet Source	1%
3	text-id.123dok.com Internet Source	1%
4	A M Ilyas, A Suyuti, I C Gunadin, S M Said. "Forecasting model of power generated by wind power plants", IOP Conference Series: Earth and Environmental Science, 2021 Publication	1%
5	Zhaohong Bie, Gan Li, Hui Liu, Xifan Wang, Xiuli Wang. "Studies on Voltage Fluctuation in the Integration of Wind Power plants Using Probabilistic Load Flow", 2008 IEEE Power and Energy Society General Meeting - Conversion and Delivery of Electrical Energy in the 21st Century, 2008 Publication	<1%
6	www.jvejournals.com Internet Source	<1%

7	dl.icdst.org Internet Source	<1 %
8	journal.uad.ac.id Internet Source	<1 %
9	journal.esrgroups.org Internet Source	<1 %
10	E I Pangastuti, E A Nurdin, R A Surya, B Apriyanto, A W Khoiroh. "Improving student learning outcomes using research-based think pair and share models", IOP Conference Series: Earth and Environmental Science, 2020 Publication	<1 %
11	ipco-co.com Internet Source	<1 %
12	"Simulated Evolution and Learning", Springer Nature, 2008 Publication	<1 %
13	Chao Chen, Linan Qu, Ming-Lang Tseng, Lingling Li, Chih-Cheng Chen, Ming K. Lim. "Reducing fuel cost and enhancing the resource utilization rate in energy economic load dispatch problem", Journal of Cleaner Production, 2022 Publication	<1 %
14	Lecture Notes in Electrical Engineering, 2014. Publication	<1 %

15

Nicholas Jenkins, Andrew Vaudin. "Wind Power Plants", Wiley, 1999

Publication

<1 %

Exclude quotes On

Exclude matches < 5 words

Exclude bibliography On